

IP-2PT-IZ04A

2MP 4x IR PTZ Network Camera



System Overview

Featuring powerful optical zoom and accurate pan/tilt/zoom performance, the camera provides a wide monitoring range and great detail. The camera delivers 4MP resolution at 25/30fps. The camera is equipped with smooth control, high quality image, and good protection, meeting compact size demands of video surveillance applications.

Features

- 1/2.7" 2Megapixel CMOS
- Powerful 4x optical zoom
- Support Triple-streams encoding
- WDR, Day/Night(ICR), Ultra DNR
- Max. 25/30fps@1080P
- IVS
- Support PoE
- IR distance up to 30m

Dimensions(mm/inch)

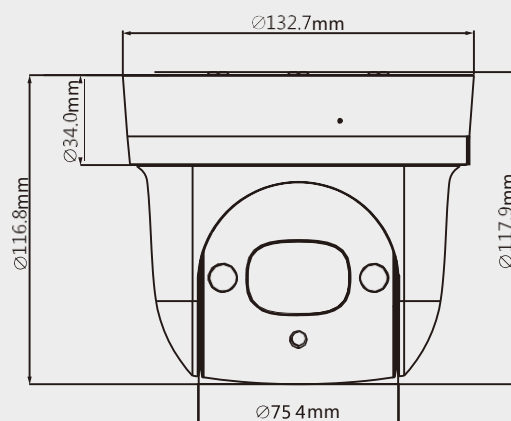

Functions

Wide Dynamic Range

The camera achieves vivid images, even in the most intense contrast lighting conditions, using industry-leading wide dynamic range (WDR) technology. For applications with both bright and low lighting conditions that change quickly, True WDR (120 dB) optimizes both the bright and dark areas of a scene at the same time to provide usable video.

Smart H.264+

Delivering high quality video without straining the network, Smart H.264+ is the optimized implementation of H.264. The Smart H.264+ encoding platform includes a scene adaptive encoding strategy, dynamic GOP, dynamic ROI, flexible multi-frame reference structure and intelligent noise reduction, providing a savings of up to 70% of bandwidth and storage when compared with standard H.264.

Environmental

The camera can function from -30°C to +60°C (-22 °F to +140°F) with 95% humidity, meanwhile some models support heater module optional which allows the camera to function from -40°C to +60°C (-40 °F to +140 °F). With a temperature range of -40 °C to +60 °C, the camera is designed for extreme temperature environments.

Interoperability

The camera conforms to the ONVIF (Open Network Video Interface Forum) and PSIA (Physical Security Interoperability Alliance) specifications, ensuring interoperability between network video products regardless of manufacturer.



IP-2PT-IZ04A

Interface

Video Interface	N/A
RS485	N/A
Audio I/O	Built-in Mic
Alarm I/O	N/A

Electrical

Power Supply	DC 12V/1.5A, PoE(802.3af)
Power Consumption	10W,13W (IR on)

Environmental

Operating Conditions	-30°C ~ 60°C (-22°F ~ +140°F) / Less than 90% RH
Ingress Protection	N/A
Vandal Resistance	N/A

Construction

Casing	Metal
Dimensions	Φ132.7 (mm) x 117.9 (mm)
Net Weight	0.95kg(2.09lb)
Gross Weight	1kg(2.20lb)

Accessories (optional)



PFB302S
Wall Mount

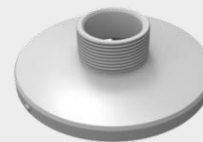

PFA103
Mount Adater



DC12V/2A
Power Adapter



PFA150
Pole Mount



PFB300C
Ceiling Mount

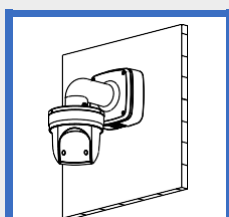

PFA103+PFB302S

Wall Mount

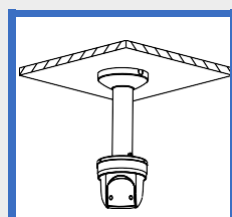

PFA103+PFB300C

Ceiling Mount

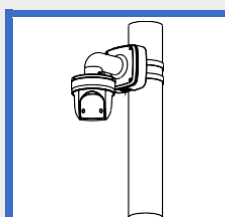

PFA103+PFB302S+PFB300C

Pole Mount